

面板安装开孔图
 Panel cut out

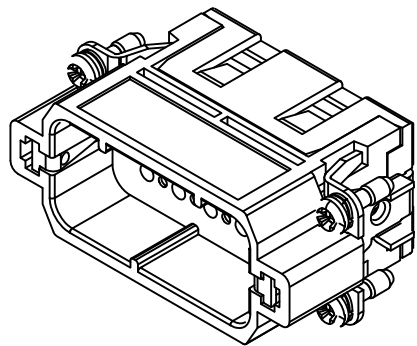

技术参数:

插芯:

- 插针数: 10+PE
- 额定电流: 16A
- 额定电压: 250V
- 额定脉冲电压: 4kV
- 污染等级: 3
- 依据UL/CSA的额定电压: 600V
- 绝缘阻抗: $\geq 10^{10}\Omega$
- 材料: 聚碳酸酯
- 颜色: RAL 7032 (浅灰色)
- 温度范围: $-40^{\circ}\text{C} - +125^{\circ}\text{C}$
- 依据UL 94的阻燃等级: V0
- 可插拔次数: ≥ 500
- 插针:
- 接线方式: 冷压连接
- 材料: 铜合金
- 表面处理:
 - 镀银
 - 镀金
- 接触电阻: $< 1\text{m}\Omega$
- 线径范围: $0.14-4.0\text{mm}^2(26-12\text{ AWG})$
- 工具:
 - 冷压钳: TL02G
 - 退针器: TL01

Technical specification:

Insters:

- No. of contact: 10+PE
- Rated current: 16A
- Rated voltage: 250V
- Rated impulse voltage: 4kV
- Pollution degree: 3
- Rated voltage acc.to UL/CSA: 600V
- Insulation resistance: $\geq 10^{10}\Omega$
- Material: polycarbonate
- Colour: RAL 7032(light grey)
- Temperature range: $-40^{\circ}\text{C} - +125^{\circ}\text{C}$
- Flammability acc.to UL 94: V0
- Mating cycles: ≥ 500
- Contacts:
- Terminal: crimp terminal
- Material: copper alloy
- Surface:
 - hard-silver plated
 - hard-gold plated
- Contact resistance: $\leq 1\text{m}\Omega$
- Wire gauge: $0.14-4.0\text{mm}^2(26-12\text{ AWG})$
- Tools:
 - Crimp contact tool: TL02G
 - Contact removal tool: TL01

						表面处理 Finish	-			图号 Drawing No.	-	
						材料 Material	-			产品代号 Part Code	HA-010-MC	
标记 Mark	处数 Number	变更描述/Description			签名 Signature	日期 Date	比例 Scale	版本 REV.	重量 Weight	数量 Qty.	产品料号 Part No.	1210100100001
绘图 Drawn	BQ LUO	姓名/Name	日期/Date	标准化 Stand.	-	-	1:1	V1.0	30.8g	-	产品名称 Part Name	-
审核 Checked	P RAO	姓名/Name	日期/Date									
工艺 Process	-	批准 Approved	YY LIN	日期/Date	18.10.2010	All Dimensions in mm Original Size DIN A 4			厦门唯恩电气有限公司 XIAMEN WAIN ELECTRICAL CO.LTD			