

日期/Date
 档案员
 Filing Clerk

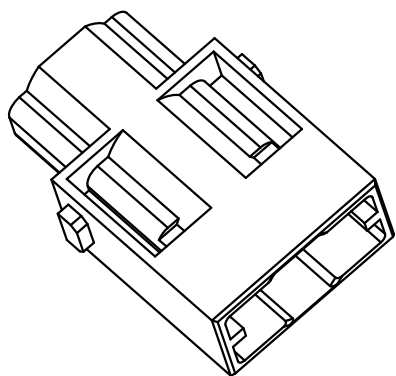
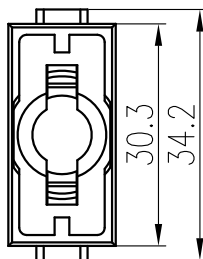
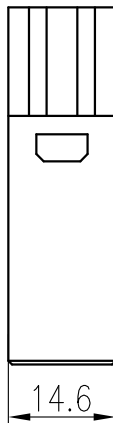
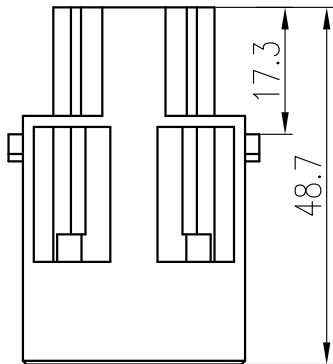

技术参数:

- 插芯:
- 插针数: 1
 - 额定电流: 100A
 - 额定电压: 830V
 - 额定脉冲电压: 8kV
 - 污染等级: 3
 - 绝缘阻抗: $> 10^{10}\Omega$
 - 材料: 聚碳酸酯
 - 颜色: RAL 7032 (浅灰色)
 - 温度范围: $-40^{\circ}\text{C} - +125^{\circ}\text{C}$
 - 依据UL 94的阻燃等级: V0
 - 可插拔次数: > 500
 - 最大绝缘直径: 13mm
- 插针:
- 接线方式: 冷压连接
 - 材料: 铜合金
 - 表面处理: 镀银
 - 接触电阻: $< 0.3\text{m}\Omega$
 - 线径范围: $10-35\text{mm}^2$
 - 工具:
 - 冷压钳: TL05
 - 退针器: TL11

Technical specification:

- Insters:
- No. of contact: 1
 - Rated current: 100A
 - Rated voltage: 830V
 - Rated impulse voltage: 8kV
 - Pollution degree: 3
 - Insulation resistance: $> 10^{10}\Omega$
 - Material: polycarbonate
 - Colour: RAL 7032(light grey)
 - Temperature range: $-40^{\circ}\text{C} - +125^{\circ}\text{C}$
 - Flammability acc.to UL 94: V0
 - Mating cycles: > 500
 - Max. insulation diameter: 13mm
- Contacts:
- Terminal: crimp terminal
 - Material: copper alloy
 - Surface: hard-silver plated
 - Contact resistance: $< 0.3\text{m}\Omega$
 - Wire gauge: $10-35\text{mm}^2$
- Tools:
- Crimp contact tool: TL05
 - Contact removal tool: TL11

						表面处理 Finish	-			图号 Drawing No.	-
						材料 Material	-			产品代号 Part Code	HMK-001-MC
标记 Mark	处数 Number	变更描述/Description			签名 Signature	日期 Date				产品料号 Part No.	1290010100001
绘图 Drawn	姓名/Name	日期/Date	标准化 Stand.	姓名/Name	日期/Date	比例 Scale	版本 REV.	重量 Weight	数量 Qty.	产品名称 Part Name	-
审核 Checked	BQ LUO	18.10.2010		-	-	1:1	V1.0	7.8g	-	厦门唯恩电气有限公司 XIAMEN WAIN ELECTRICAL CO.LTD	
工艺 Process	-	-	批准 Approved	YY LIN	18.10.2010			All Dimensions in mm Original Size DIN A 4			