

日期/Date		档案员 Filing Clerk		1		2		3		4		5		6		
产品代号 Part code	产品料号 Part NO.	重量/Weight g	线径/Wire Gauge mm ² AWG		d	D	剥线长度 Stripping length	标识 Identification	标识图 Identification No.	No.	No.1	No.2	No.3	No.4	No.5	No.6
CESF-0.37	1010191200301	1.37	0.14-0.37	26-22	0.90	1.8	7.5	no groove	No.1	标示图 Marked Graph						
CESF-0.50	1010191200401	1.52	0.5	20	1.15	2.6	7.5	no groove	No.1							
CESF-0.75	1010191200601	1.54	0.75	18	1.30	2.6	7.5	1 groove	No.2							
CESF-1.0	1010191200801	1.54	1.0	18	1.45	2.6	7.5	1 groove	No.3							
CESF-1.5	1010191200901	1.58	1.5	16	1.75	3.0	7.5	2 groove	No.4							
CESF-2.5	1010191201001	1.62	2.5	14	2.25	3.5	7.5	3 groove	No.5							
CESF-3.0	1010191201101	1.54	3.0	12	2.55	3.7	7.5	wide groove	No.6							
CESF-4.0	1010191201201	1.55	4.0	12	2.85	3.9	7.5	no groove	No.1							

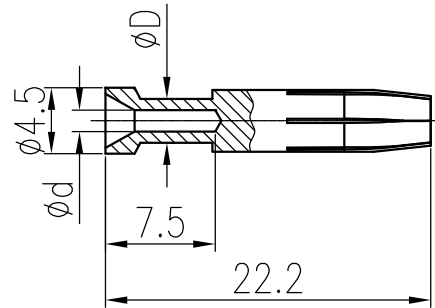

技术参数:

- 材料: 铜合金
- 表面处理: 镀银
- 额定电流: 16A
- 接触电阻: $\leq 1\text{m}\Omega$
- 线径范围: $0.14-4.0\text{mm}^2(26-12 \text{ AWG})$
- 可插拔次数: ≥ 500

Technical specification:

- Material: copper alloy
- Surface: hard-silver plated
- Rated current: 16A
- Contact resistance: $\leq 1\text{m}\Omega$
- Wire gauge: $0.14-4.0\text{mm}^2(26-12 \text{ AWG})$
- Mating cycles: ≥ 500

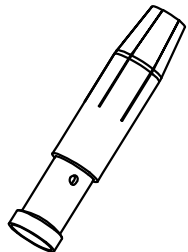

						表面处理 Finish		-		图号 Drawing No.		-	
						材料 Material		-		产品代号 Part Code		CESF-XX	
标记 Mark		处数 Number		变更描述/Description		签名 Signature		日期 Date		产品料号 Part No.		-	
姓名/Name		日期/Date		姓名/Name		日期/Date		比例 Scale		版本 REV.		重量 Weight	
BQ LUO		18.10.2010		标准化 Stand.		-		-		2:1		V1.0	
审核 Checked		P RAO		18.10.2010						数量 Qty.		-	
工艺 Process		-		批准 Approved		YY LIN		18.10.2010		All Dimensions in mm Original Size DIN A 4		-	
												厦门唯恩电气有限公司 XIAMEN WAIN ELECTRICAL CO.LTD	