

日期/Date
 档案员
 Filing Clerk

技术参数:

- 材料: 铜合金
- 表面处理: 镀银
- 额定电流: 350A
- 接触电阻: $\leq 0.3m\Omega$
- 线径范围: $50mm^2$
- 剥线长度: 28mm
- 最大电缆直径: 22mm
- 冷压模具: 按照 DIN 46 235
- 压力要求: 130kN
- 可插拔次数: ≥ 500

Technical specification:

- Material: copper alloy
- Surface: hard-silver plated
- Rated current: 350A
- Contact resistance: $\leq 0.3m\Omega$
- Wire gauge: $50mm^2$
- Stripping length: 28mm
- Max. insulation diameter: 22mm
- Crimp dies: acc. to DIN 46 235
- Pressing force: 130kN
- Mating cycles: ≥ 500

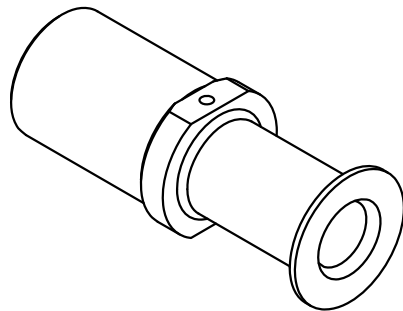
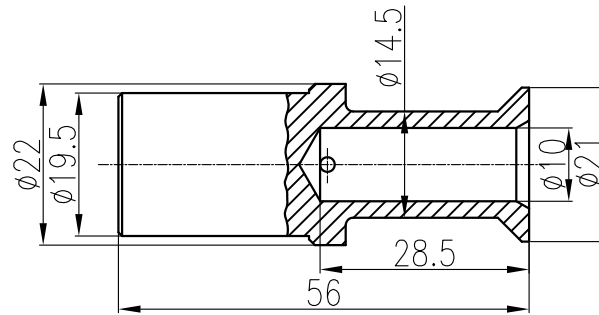

						表面处理 Finish		-		图号 Drawing No.	-	
						材料 Material		-		产品代号 Part Code	CHSF350-50G	
标记 Mark	处数 Number	变更描述/Description		签名 Signature	日期 Date	比例 Scale		版本 REV.	重量 Weight	数量 Qty.	产品料号 Part No.	
绘图 Drawn	BQ LUO	姓名/Name	日期/Date	姓名/Name	日期/Date	1:1	V1.0	74g	-	-	1010291201803	
审核 Checked	P RAO	姓名/Name	日期/Date	姓名/Name	日期/Date						产品名称 Part Name	
工艺 Process	-	姓名/Name	日期/Date	批准 Approved	YY LIN	18.10.2010						
									All Dimensions in mm Original Size DIN A 4			厦门唯恩电气有限公司 XIAMEN WAIN ELECTRICAL CO.LTD