

日期/Date  
 档案员  
 Filing Clerk

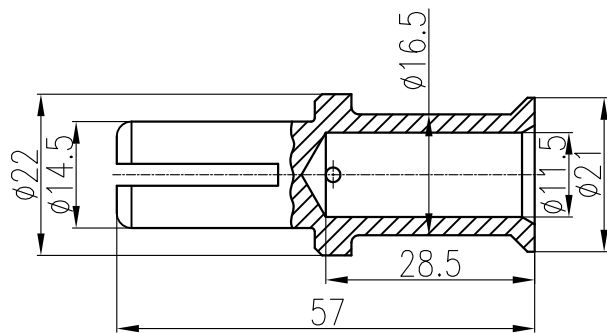

技术参数:

- 材料: 铜合金
- 表面处理: 镀银
- 额定电流: 350A
- 接触电阻:  $\leq 0.3m\Omega$
- 线径范围:  $70mm^2$
- 剥线长度: 28mm
- 最大电缆直径: 22mm
- 冷压模具: 按照 DIN 46 235
- 压力要求: 130kN
- 可插拔次数:  $\geq 500$

Technical specification:

- Material: copper alloy
- Surface: hard-silver plated
- Rated current: 350A
- Contact resistance:  $\leq 0.3m\Omega$
- Wire gauge:  $70mm^2$
- Stripping length: 28mm
- Max. insulation diameter: 22mm
- Crimp dies: acc. to DIN 46 235
- Pressing force: 130kN
- Mating cycles:  $\geq 500$

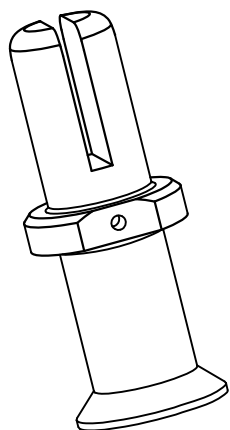

						表面处理 Finish		-		图号 Drawing No.	-
						材料 Material		-		产品代号 Part Code	CHSM350-70
标记 Mark	处数 Number	变更描述/Description		姓名/Name	日期/Date	比例 Scale	版本 REV.	重量 Weight	数量 Qty.	产品料号 Part No.	1010291101901
绘图 Drawn	BQ LUO	18.10.2010	标准化 Stand.	-	-	1:1	V1.0	66.8g	-	产品名称 Part Name	-
审核 Checked	P RAO	18.10.2010									
工艺 Process	-	-	批准 Approved	YY LIN	18.10.2010			All Dimensions in mm Original Size DIN A 4		厦门唯恩电气有限公司 XIAMEN WAIN ELECTRICAL CO.LTD	