

电缆直径:D8
 Cable outlet:D8

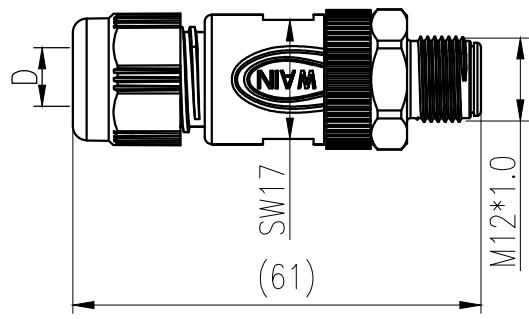

针位排布图

Contact arrangement

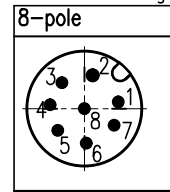

技术参数:

- 产品系列: M12-A 编码
- 插针数: 8
- 额定电流(40°C): 2A
- 额定电压: 60V
- 额定脉冲电压: 800V
- 污染等级: 3
- 接触电阻: ≤10mΩ
- 防护等级: IP67
- 插拔次数: >100
- 温度范围: -40°C...+85°C
- 绝缘阻抗: >100MΩ
- 接线方式: 螺钉锁紧
- 线径范围: max.0.5mm² (max.AWG20)
- 锁紧扭矩: 0.2Nm (螺钉接线)
- 电缆直径: 6-8mm
- 电缆剥线长度: 20mm
- 导线剥线长度: 5mm

Technical specification:

- Series: M12 A-Code
- Number of contacts: 8
- Rated current(40°C): 2A
- Rated voltage: 60V
- Rated impulse voltage: 800V
- Pollution degree: 3
- Contact resistance: ≤10mΩ
- Degree of protection: IP67
- Mating cycles: >100
- Temperature range: -40°C - +85°C
- Insulation resistance: >100MΩ
- Termination method: screw connection
- Wire gauge: max.0.5mm² (max.AWG20)
- Torque: 0.2Nm (screw terminal blocks)
- Cable Outlet: 6-8mm
- Stripping length of the sheath: 20mm
- Stripping length of the individual wire: 5mm

材料特性:

- 锁紧螺帽: 不锈钢
- 插针材料: 铜合金
- 插针表面处理: 镀金
- 外壳材料: PA
- 颜色: RAL 9005 (黑色)
- 绝缘材料: PA

Material properties:

- Material of locking system: Stainless steel
- Material of contact: copper alloy
- Contact plating: Au
- Material of housing: PA
- Colour of housing: RAL 9005 (Black)
- Material of Insert: PA

符合标准: IEC 61076-2-101

Standards: IEC 61076-2-101

						表面处理 Finish	-			图号 Drawing No.	-
						材料 Material	-			产品代号 Part Code	M12S-M08A-T-D8
标记 Mark	处数 Number	变更描述/Description		签名 Signature	日期 Date					产品料号 Part No.	1630084113202
	姓名/Name	日期/Date		姓名/Name	日期/Date	比例 Scale	版本 REV.	重量 Weight	数量 Qty.	产品名称 Part Name	-
绘图 Drawn	ZM LIN	22.09.2015	标准化 Stand.	-	-	1:1	V1.0	25.7g	-		
审核 Checked	YY LUO	22.09.2015									
工艺 Process	-	-	批准 Approved	YY LUO	22.09.2015	All Dimensions in mm Original Size DIN A 4			厦门唯恩电气有限公司 XIAMEN WAIN ELECTRICAL CO.LTD		