

技术参数:

- 插针数: 4
- 额定电流: 40A
- 工作电压: 250V (AC)
- 耐压: 2.0KV (常温状态)
- 绝缘电阻: $\geq 2000\text{M}\Omega$ (常温状态)
- 接触电阻: $\leq 0.75\text{m}\Omega$
- 焊线规格: $2.0\text{mm}^2\text{--}4.0\text{mm}^2$ (焊线筒直径 $\phi 2.7\text{mm}$)
- 外壳材料: 铜合金镀镍
- 插针材料: 铜合金镀金
- 绝缘件: 热固性材料
- 振动: $10\text{--}2000\text{Hz}, 147\text{m/s}^2$, 瞬断 $\leq 1\text{us}$
- 冲击: 加速度峰值 490m/s^2 , 瞬断 $\leq 1\text{us}$
- 机械寿命: ≥ 500
- 锁定方式: 螺纹锁定
- 相对湿度: $90\%\text{--}95\%$ ($40^\circ\text{C}\pm 2^\circ\text{C}$ 时)
- 工作温度: $-40^\circ\text{C}\dots+105^\circ\text{C}$
- 防护等级: IP65

Technical specification:

- Number of contacts: 4
- Rated current: 40A
- Rated voltage: 250V (AC)
- Rated impulse voltage: 2.0KV(normal temperature)
- Insulation resistance: $\geq 2000\text{ M}\Omega$ (normal temperature)
- Contact resistance: $\leq 0.75\text{ m}\Omega$
- Welding wire: $2.0\text{mm}^2\text{--}4.0\text{mm}^2$ (Diameter $\phi 2.7\text{mm}$)
- Material of housing: The copper alloy plating nickel
- Material of contact: Gold-plated copper alloy
- Material of insert: Thermosets
- Vibration: Frequency $10\sim 2000\text{Hz}$,accelerated speed 147m/s^2 , instant break $\leq 1\text{us}$
- Shock: Accelerated speed 490m/s^2 , instant break $\leq 1\text{us}$
- Mating cycles: ≥ 500
- Connector locking system: Thread locking
- Relative humidity: $90\%\sim 95\%$ ($40^\circ\text{C}\pm 2^\circ\text{C}$)
- Working temperature: $-40^\circ\text{C}\text{--}+105^\circ\text{C}$
- Pollution degree: IP65

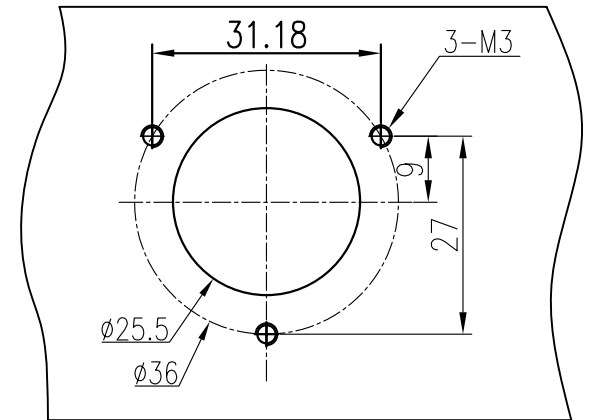
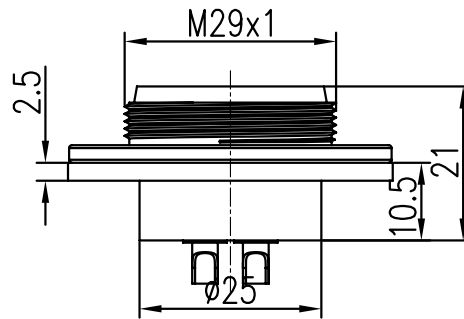

面板安装尺寸
 Panel Cut-out

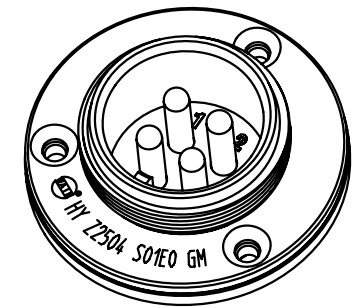
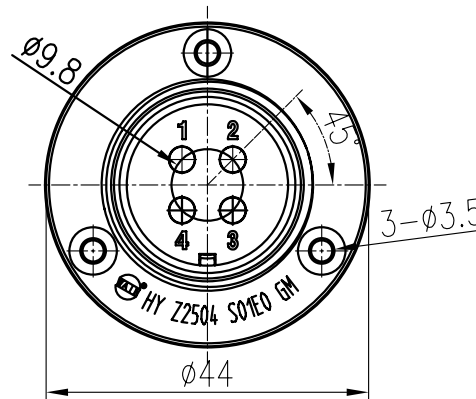

						表面处理 Finish	-				图号 Drawing No.	-
						材料 Material	-				产品代号 Part Code	HY-Z2504-S01E0-GM
标记 Mark	处数 Number	变更描述/Description			签名 Signature	日期 Date	比例 Scale	版本 REV.	重量 Weight	数量 Qty.	产品料号 Part No.	1690043131001
绘图 Drawn	HQ ZHANG	姓名/Name	日期/Date	标准化 Stand.	-	1:1	V1.0	58.5 g	-	产品名称 Part Name	-	
审核 Checked	ZM LIN	姓名/Name	日期/Date									
工艺 Process	-	姓名/Name	日期/Date	批准 Approved	YY LUO	08.07.2014	All Dimensions in mm Original Size DIN A 4				厦门唯恩电气有限公司 XIAMEN WAIN ELECTRICAL CO.LTD	